

proFIL™ series of Antenna Power Injectors

proFIL™ filters offer a superb way to combine multiple radios into a single antenna. High performance proFIL™ technology enables modern communications without compromising safety and performance.



proFIL 1320 an active Navtex antenna (0.1MHz-30MHz) power feeder. It is intended to be used when MF/HF DSC receiver or Navtex receiver is connected to an active receive antenna and receiver itself cannot source power to antenna.

When Navtex is a GMDSS requirement for the vessel, authorization to use proFIL kind of power injectors have to be obtained from the local maritime authority or classification society.

Operation

proFIL™ 1320 antenna feeder has internal interference protected power supply that converts vessels 9-36VDC input to 10VDC antenna feed. It has no wearing or serviceable parts. Thus maximizing the reliability.

It causes no losses to signal itself and all ports are galvanic isolated in order to protect from ground leaks.

The amplifier is powered through separate 9-36VDC power feed. The internal power supply/converter is fully galvanic isolated and this creates no risk to ground leaks. Antenna and receiver ports are DC floating from the body.

Connection example

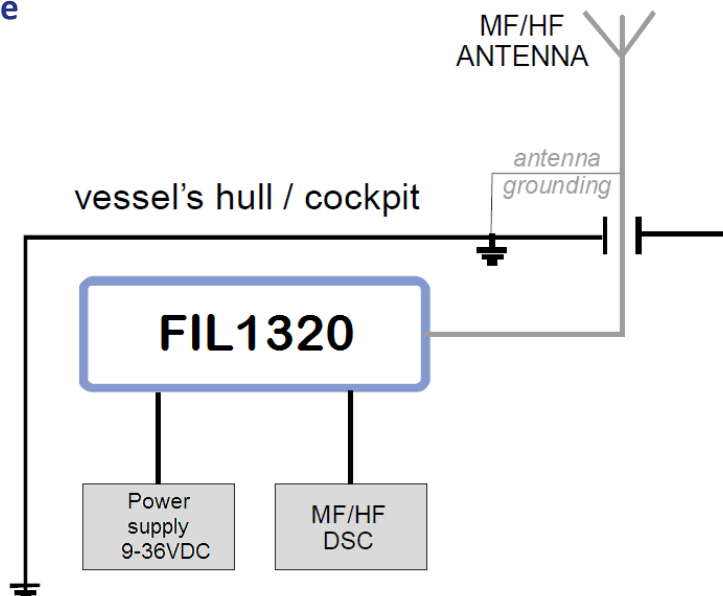

proFIL™ series of Antenna Power Injectors

Table 1 Electrical Specifications

Electrical Specifications (TA=25°C)	proFIL 1320
Antenna Port	0.1 MHz – 30 MHz
Radio Ports	RX 1: 0.1 MHz – 30 MHz (isolated from body)
Operation	Isolated low noise active antenna power injector
Power Handling (max simultaneous)	0.1W
Port Isolation (between outputs)	-
Port impedance	50 Ω
Connectors	N-female
Resistance to ground	Antenna port isolated from the body, RX port grounded
Power input	9 – 36 VDC
Power output via ANT port	9V, 100mA isolated supply

Table 2 Mechanical and Environmental properties

Mechanical and Environmental properties (TA=25°C)	proFIL1320
Dimensions	height: 30mm width: 119mm depth: 110mm
Weight	about 320g
Material	Aluminium body
Ingress protection	none
Mounting	wall mounting flanges with M4 holes

